

Product Description

Technical Data:

1. Battery life span: 12~16 months
2. Card Type: ATMELEMIC induction card
3. Starting time: <1 second
4. Master card capacity: 2
5. Guest card capacity: 200
6. Working Voltage: Direct current 6V, 4pcs alkaline batteries
7. Static power consumption: <4 μ A
8. Dynamic power consumption: around 200 mA
9. Working temperature: -20 to 50 centigrade

Hotel key card lock on sale

10. Working humidity: \leq 80%
11. Unlocking card: sensor cards
13. door thickness: from 30~50mm
14. Unlocking record: Saving the last 1000 pcs unlocking records(including key unlocking)
15. Sensor distance: 3~5cm
16. Lock net/gross weight: 2.9~3.5 kgs/4kgs-4.5kgs
17. voltage alarm: yes, less than 4.8V lock will alarm to indicate.
18. Fake closing alarm: yes

Hotel safe supplier china





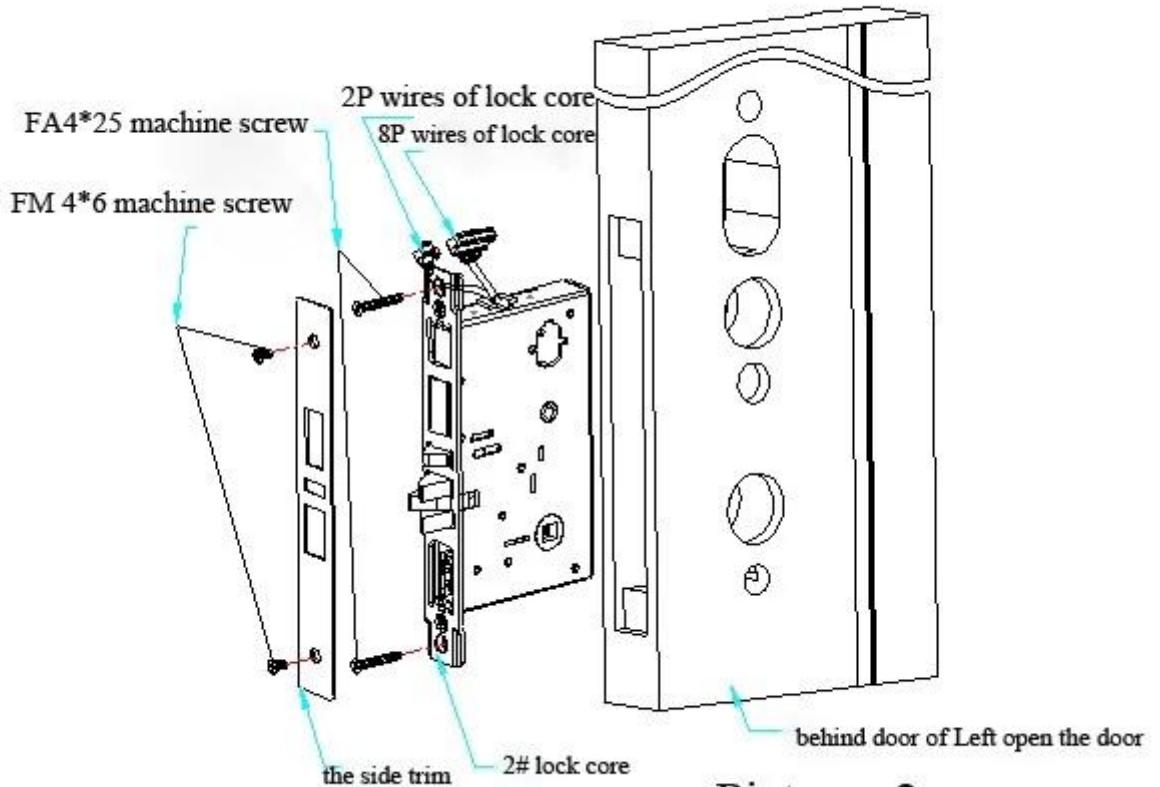

Pictures 2

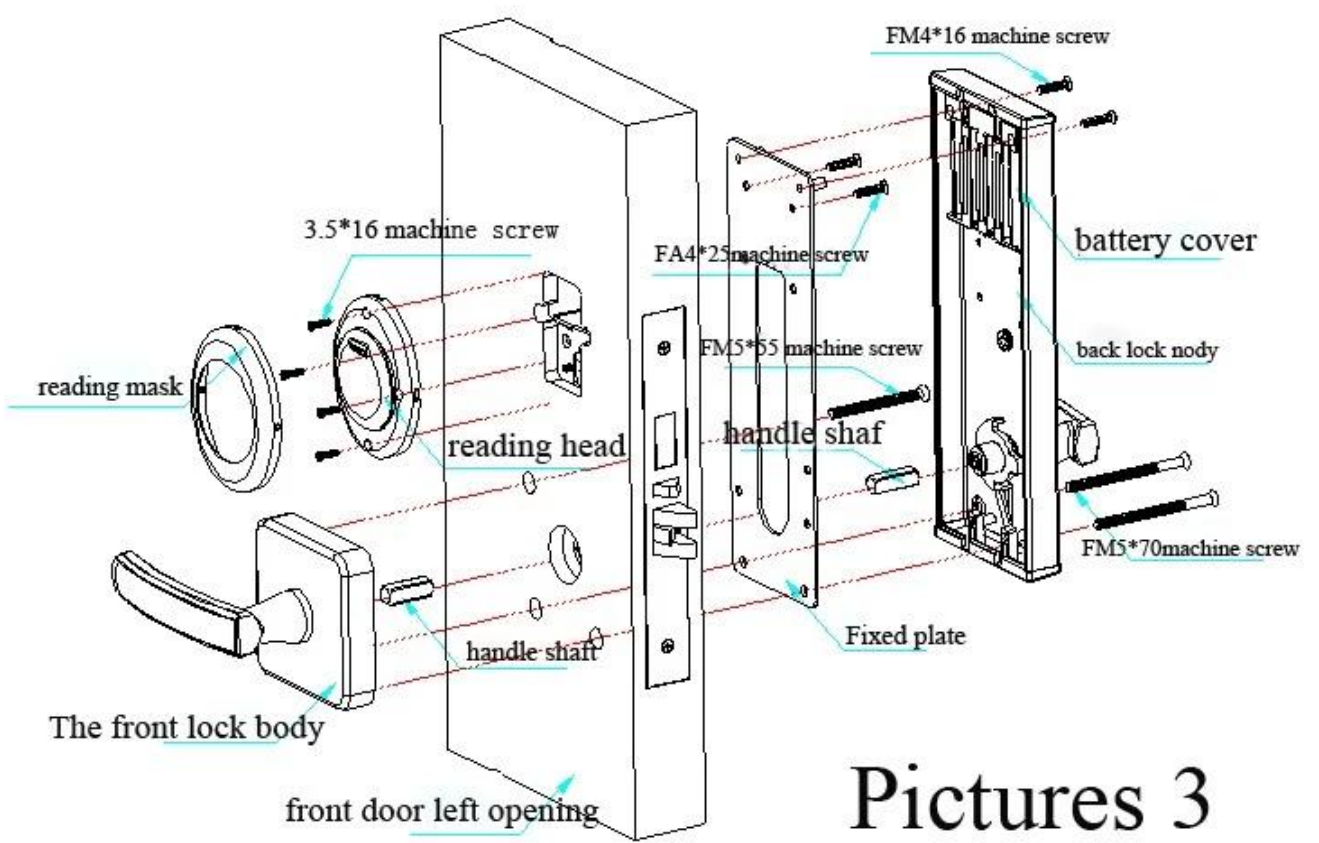

Pictures 3





感应卡取电

INSERT CONTACTLESS CARD
FOR POWER

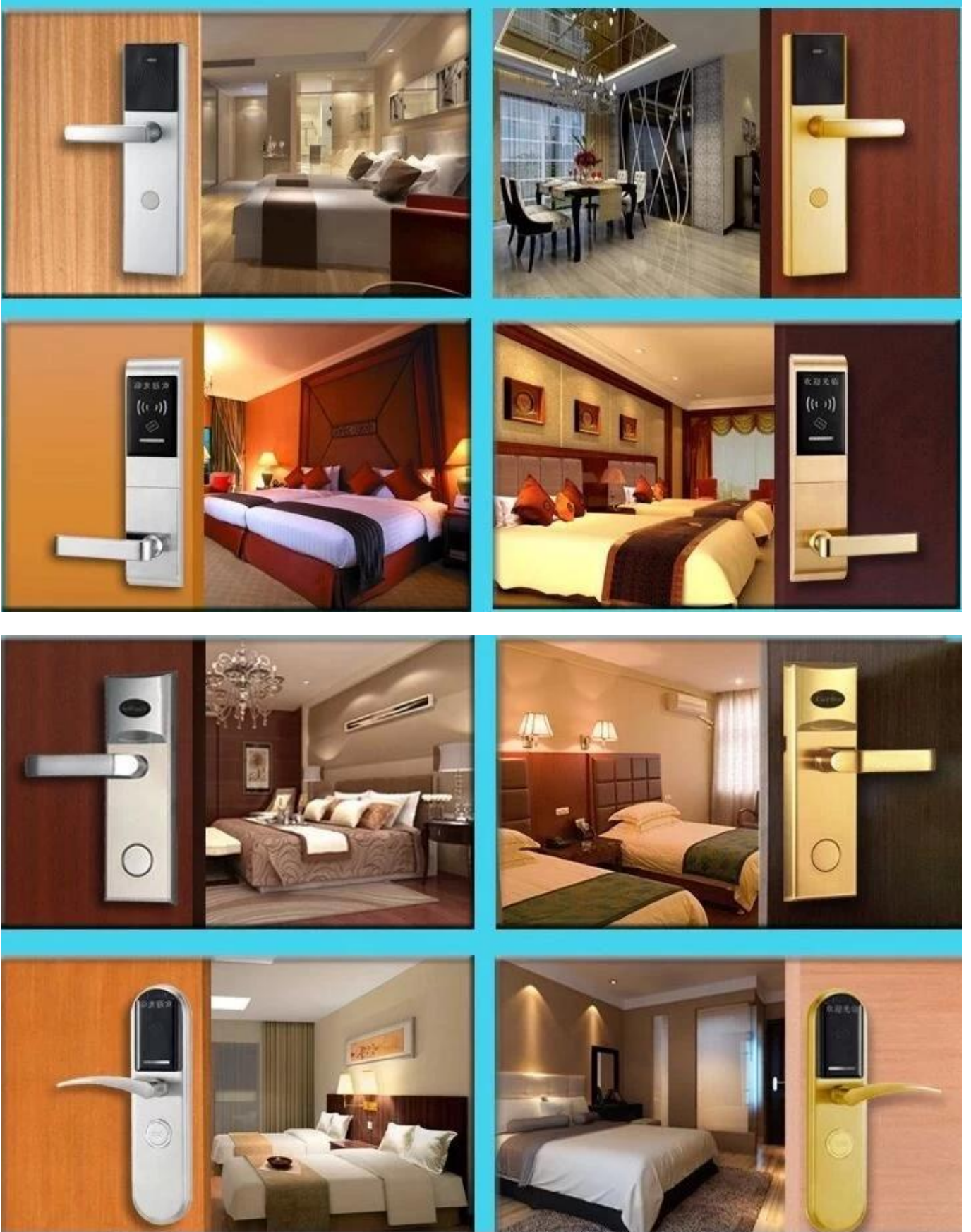

Our team

As a professional manufacturer of secure password steel China, our main independent research and development products are advanced fingerprint lock, combination lock, security lock, hotel door lock system, smart locker sauna cabinet, keypad lock, lock e-Cabinets that are widely used in the hotel access control system, massage center, office building, apartment, villa, etc.



certifications



We have already passed and executed ISO9001: 2000. In addition, our product has CE, FCC, ROHS and some Chinese quality certificates, etc.

Why Choose Us

1. Market shares

we have covered the 42% of china digital locker lock market.

2. Research & Design

We have over 200 patents in total and newly increase 20 patents every year due to our major investment in R&D.

3. Quality Protection

We build a series of strict quality control system from OQC, IPQC, FQC to IQC and we have certifications of FCC, EC, RHOS and so on. 100% product quality protection for online orders.

4. Trade assurance

Your payment is locked until you confirm delivery and satisfaction. You could even get full refund if you are not satisfied with the products. 100% payment protection for online orders,

5. Diversified service

We are factory specialized in smart lock area for over 12 years providing service of OEM, ODM, retail and wholesale as well with best cost performance from factory to clients.

6. On time shipment

We assurance the shipment and lead time ahead of your deadline as we discussed. 100% on-time shipment protection for online orders.

7. After Sales Service

1 Year warranty and life time maintenance.

We are professional manufacturer in China and specializing in various of hotel locks,digital code locks,biometric lock,home safes,hotel room safe,gun cabinets,deposit safe,below ground safe etc.Welcome to visit our facility.